



Configured Valve Trains

Model VT04 (1" N.P.T.)

Version 1

The Eclipse configured valve trains use a variety of shut-off valves, regulators, and associated components. These valve trains are rated for 110-120V / 50-60 Hz operation and are designed to meet the requirements of NFPA 86 - 2003 or Industrial Risk Insures (IRI) IM.4.2.0. The IRI version includes either a vent valve or a valve proving system. Standard components of all valve train sizes include safety shut-off valves, manual shut-off valves, high & low pressure switches, visual position indicators and pressure taps for valve seat leak testing and in-line strainers. Optional components consist of regulators, valve leak test systems, upstream and downstream gauges (2½" face diameter) and pilot gas trains (1/2" or 3/8").

A standard configured valve train ordered with or without an agency designation does not guarantee compliance or non-compliance with the standard. The end-use application for the valve train determines any additional requirements to meet full compliance to the standards such as:

- Some components may require vent lines to a safe outside location.
- The customer gas supply shall have an isolation valve followed by a vertical drip leg of 3 pipe diameters but not less than 3".
- Also, external control devices may be used to meet the requirements of a standard. In this case, the valve train may need to be ordered with option X for NONE under Agency Approval to allow the most versatility in selection of component options.

Component***	Enclosure Rating (NEMA)	Max. Operating Pressure PSI	Temperature Limits °F	Agency					Comments
				U L L	U L R	C S A	F M E	C	
Eclipse 2000 AT Valves	1,2,3,3S,4,12&13	30	-20 to 150	•	•	•	•	•	Iron Body
Dungs Dual Block Valve	1 & 12	7	-40 to 150		•	•	•	•	Aluminum Body
Siemens VGG w/ SKP Actuators	1,2,5 & 12	20	15 to 140	•		•	•		Aluminum Body
Manual Shut Off Valves	N/A	600	-40 to 366	•		•	•		Brass w/ teflon seals
Pressure Switches*	1,4 & 12	7	-40 to 140	•		•	•		Auto or Manual Reset
Vent Valve (3/4")	1,2,3,3S,4 & 4X	5	-40 to 125	•		•			Aluminum Body
Valve Proving System (VDK)	12	5	15 to 140		•	•	•		Aluminum Housing
Valve Proving System (VPS)	12	7	5 to 140		•		•		Aluminum Housing
Pressure Regulator (Sensus)**	N/A	15, 125, 150	-20 to 150						Cast Iron Body
Pressure Regulator (FRI)	N/A	7	5 to 160		•	•	•		Aluminum Housing

* Switches for 40"-200" w.c. are rated for 14 psi max. and -22°F to 140°F.

** Operating Pressure depends on Model selected.

*** Refer to manufacturer's data sheets for specific component details.

Dimensions & Specifications

Eclipse Safety Shut Off Valves

NFPA

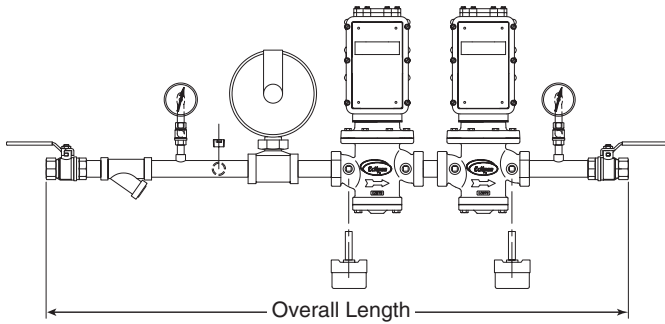

IRI

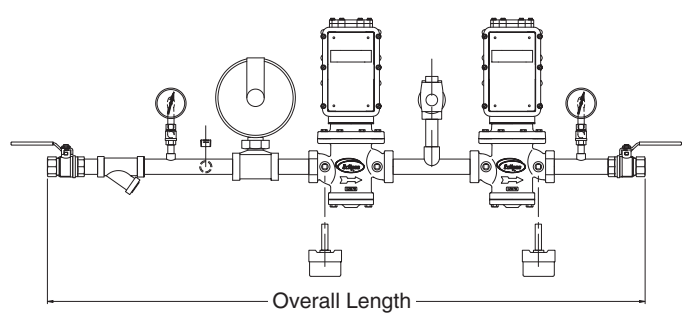

Dungs Dual Modular Shut Off Valve

NFPA

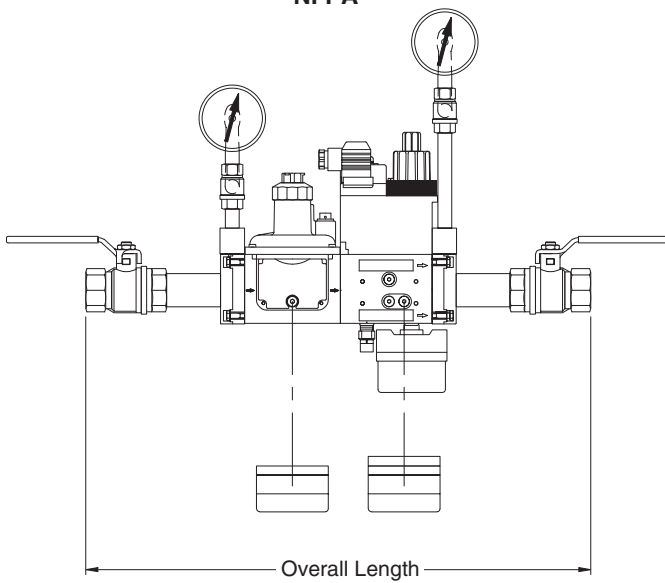

IRI

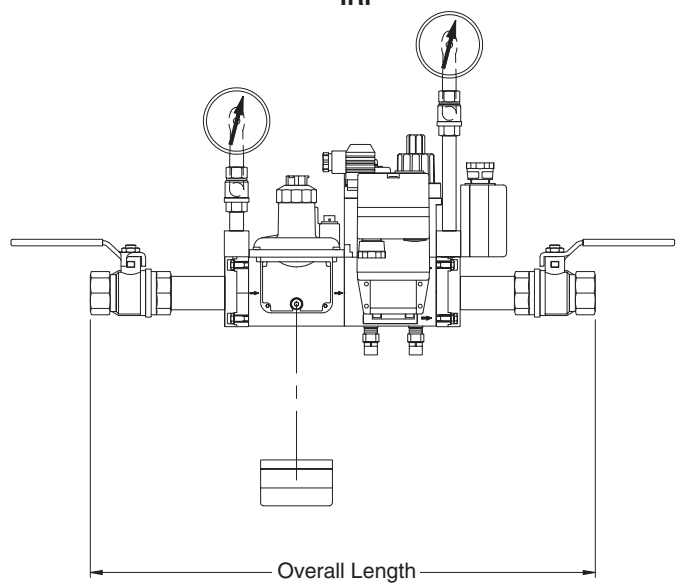

Siemens Shut Off Valves

NFPA

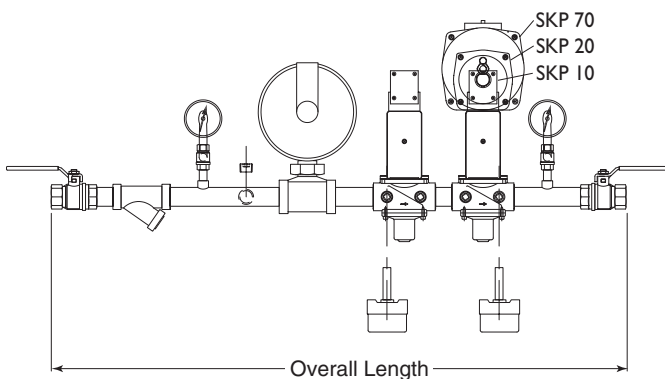

IRI

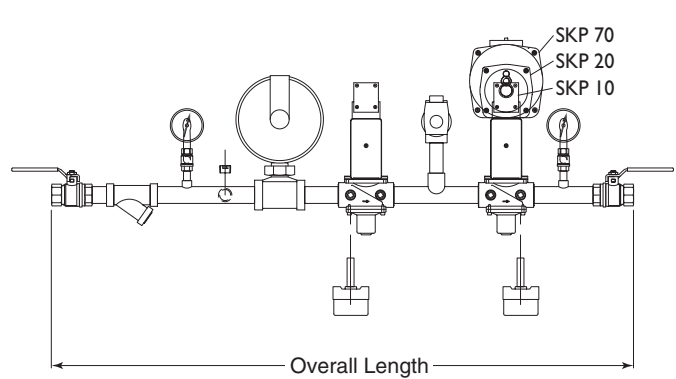

When using the Siemens SKP20 and SKP70 actuators for pressure regulating and ratio regulating functions, the sensing piping is not included. For proper operation, the sensing pipe should be at least 1/4" I.D. and connected a minimum of 5 pipe diameters downstream in a non-turbulent area.

WARNING: For proper and safe operation, the installer must read and thoroughly understand the Siemens Technical Instructions 155-514P25 for the SKP20 and 155-516P25 for the SKP70.

Dimensions & Specifications (Continued)

1" N.P.T. Valve Train Arrangements	Overall Length		ΔP ("w.c.) through (2) Safety Shut-off Valves @ 1100 scfh	Enclosure Rating (NEMA)	Temperature Range (° F)	SSOV Maximum Operating Pressure (PSI)**
	Minimum	Maximum				
Eclipse NFPA	1109 mm (43.7")	1225 mm (48.2")	1.23	4	-20 to 140	7
Eclipse IRI* w/ Vent Valve	1249 mm (49.2")	1365 mm (53.7")	1.23	4	-20 to 125	5
Dungs Dual NFPA	481 mm (18.9")	531 mm (20.9")	5.53	12	5 to 140	7
Dungs Dual IRI	481 mm (18.9")	531 mm (20.9")	5.53	1	5 to 140	5
Siemens NFPA	963 mm (37.9")	1079 mm (42.5")	2.8	12	15 to 140	7
Siemens IRI w/ Vent Valve	1103 mm (43.4")	1219 mm (48.0")	2.8	12	15 to 140	5

*Eclipse IRI with valve proving system valve differs with an enclosure rating of NEMA 12, a temperature range of 15° to 140° F, and a shorter overall length.

** Depends on components selected, pressure switches. etc.

Capacities

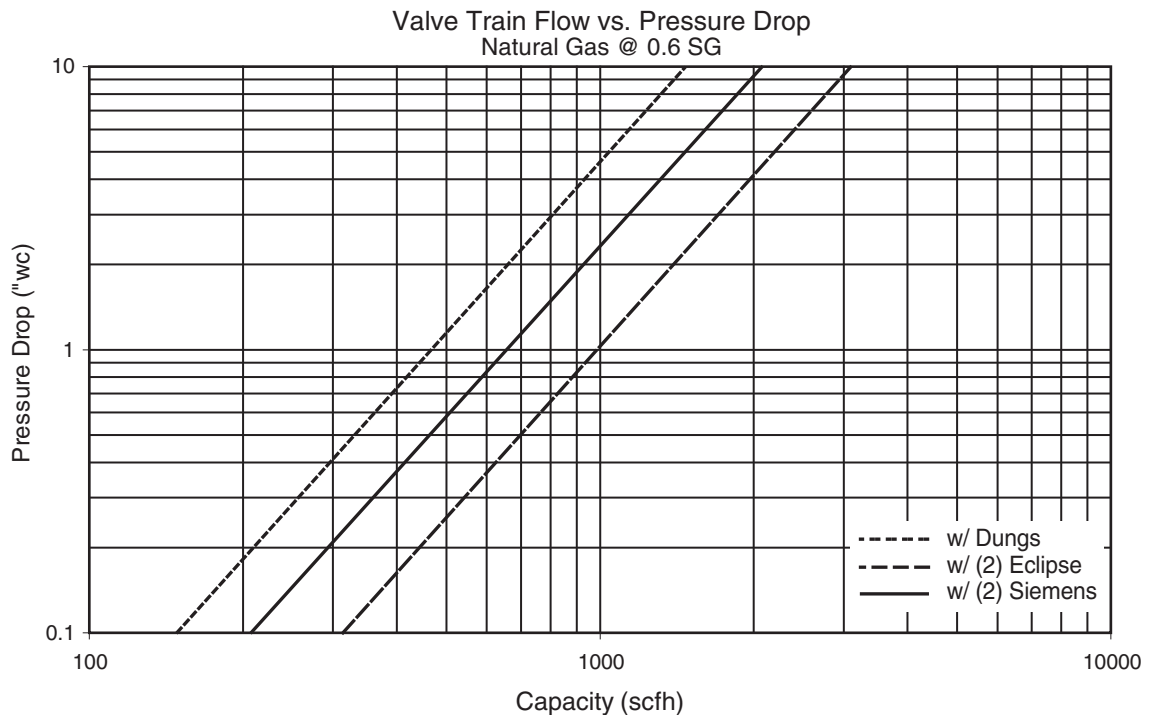



Offered By:

Power Equipment Company
2011 Williamsburg Road
Richmond, Virginia 23231
Phone (804) 236-3800
Fax (804) 236-3882

www.peconet.com